

The Club Loses Two Inspired Mechanics

John Frazee 3/6/1942 to 1/25/2022

John was many things to the club: twice president, for many years tour chairman, librarian, and So. Cal. Rep., but not once was he membership chair.. officially. He did, however, bring dozens of people into the club, first with his family, of which they were numerous, but later, friends, and strangers who soon became friends, as he was always willing to lend a helping hand, share a laugh, and give directions to the nearest bakery or ice cream shop for treats.

He enjoyed Shop Class at Oceanside High, but as a Model A Mechanic, he was largely self-taught, unafraid to experiment and a voracious reader. He, Emmett Cilley, Neb Milbourn, and Stoney Stonebreaker



formed their own parts business: Jen's just to stock parts so local restorers wouldn't have to wait to have the items shipped.

John is survived by wife, Dianne, daughter, Lisa, son, David, grandchildren, Andy, Alyssa, Fernando, Jose, and Diego, and two great grandchildren, Bodie and Boone.

Brian Treserdern 5/26/1941 to 2/7/2022

Brian grew up Northeast of London in the town of Dagenham. He learned to be a mechanic and he and a friend used their skills to apply to immigrate to the U.S. His friend got in, but he was delayed. In the months afterwards, he convinced Pam to join him and in 1963 they were married, in 1964 they moved to Riverside where he worked repairing Volvos for forty years, and in 1965, they had their son, Chris.

In retirement, Brian wanted to get a car like the ones he had first learned to work on, so he bought his '29 AA stakebed, which he named *Maggie*. In 2011, the couple joined the Palomar A's and soon after he

served as the tech director, but that same year, 2013, he was diagnosed with cancer for the first time.

He had many setbacks over the years, but he always had hopes of returning to drive *Maggie* on tours with his club friends.

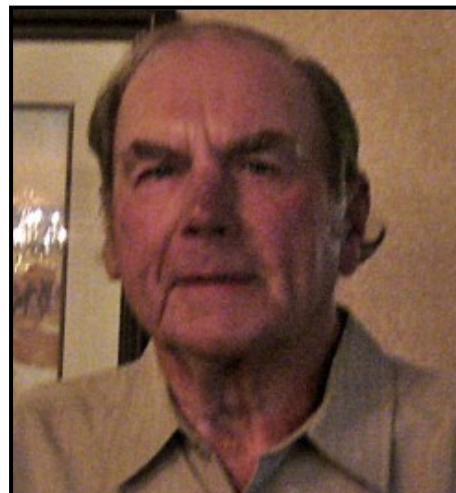

Vol. 50, No. 3

March 2022

CONTENTS

- OBITUARIES [PAGE 1](#)
- ED'S MESSAGE [PAGE 2](#)
- FEBRUARY MINUTES [PAGE 3](#)
- FEBRUARY TOUR TO SWAMI'S [PAGE 4](#)
- LONG TOURS OF '22 [PAGE 4](#)
- UNDERSTANDING THE FORD VISCOSITY CUP [PAGE 5](#)
- THE OSCAR STATUE [PAGE 6](#)
- CLUB CHANGES TO CONSIDER—MAILING *THE REFLECTOR* [PAGE 6](#)
- MARCH LUNCH TOUR TO FAT IVOR'S BARBEQUE [PAGE 7](#)
- 2022 MEMBER HANDBOOK COMPLETED [PAGE 7](#)
- ADVERTISERS [PAGE 8](#)
- MARCH CALENDAR [PAGE 9](#)

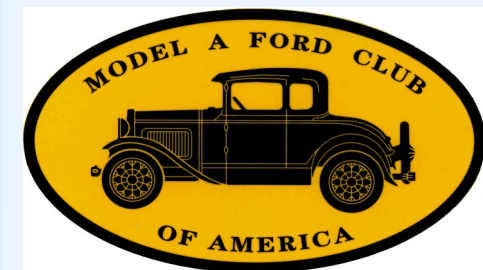

Palomar Model A Ford Club Reflector

The Message from President Ed



Greetings

February's meeting proved to be another lively one. It started a little late as most members were involved in catchup conversations and who wants to do business when there's cars to talk about.

On a sober note, the passing of John Frazee was observed with a moment of silence. John leaves us with a big gaping void in our hearts and membership. Condolences to his family and friends. For me, John was the go-to guy for all subject Model A.

He possessed a wealth of knowledge of knowledge of local history as well. He seemed to always have a little "back story," a good natured "slant" on the matter. Stories of his tour planning, leadership, and road knowledge, I'm sure will be repeated, over and over. RIP John, you are going to be missed.

The meeting passed quickly. We took care of business in an orderly manner. We had an abundant raffle, thanks to all of your contributions. Keep bringing them in. The refreshments were tasty and everything left tidy. Thanks to all of you that make it easy. If I missed anything, read the minutes printed within, Linda takes excellent notes.

Perhaps the most important issue of the night was that hard copy additions of The Reflector are being sent to people who are also receiving digital ones. Reducing duplicity will save our editor a trip to the printer, paper, and postage. David has enough on his plate.

Howard Kruegel identified a cast aluminum mystery object brought in by David F. as a bung wrench. Next month, Chuck Grabowski is going to give a tech talk on a new-school starter he installed. After that, Greg Wilson is up for some low tech.

Our Treasurer says that we are awash in money, and we need to spend some. How about a catered picnic? Some hired infotainment? For just a couple of sug-

gestions. We can use plenty more.

Linda is not going to be here next month, so we need a substitute secretary. We will give you lots of help. By the time you read this, we should have shared some good times in downtown Vista over lunch. See calendar for details.

Back to that jerky journey of mine in a roadster pickup. Dad's new pickup with the motor from the old one worked fine. It took him back and forth to work ten miles each way for many years. Rain or shine, it never missed a beat. It always started on command and never was left out of the garage. We could always hear him coming home from blocks away. My mother would always worry as it only had a primitive hand crank windshield wiper and occasionally shimmied violently upon hitting a bump crooked. Our truck was well known in the neighborhood and it was frequently loaded up full of kids off to a picnic or school event. Meanwhile, the old roadster pickup rested quietly, back in the "South Forty" along with piles of old fence posts, rusty iron, and chicken

equipment. As a little boy, I could be frequently found sitting out back in that rusty wreck, perfecting my H-Pattern shifting routine and practicing proper arm signal techniques. Stay tuned...

Ed Simpson.

Minutes of the Meeting

Call To Order: The February 2, 2022 meeting of the Palomar Model A Ford Club was called to order by President Ed Simpson at 7:05 p.m. We had 30 Club members in attendance. The Pledge of Allegiance was lead by Chuck Grabowsky. Our first order of business was to have a moment of silence for long-time member John Frazee, who passed away on February 25th.

Minutes: Secretary Linda Thamer said the minutes of the January meeting were printed in the Reflector, and she asked if everyone had received it. After asking for a motion to accept the minutes as printed, Karen Beel made a motion, seconded by Joe Williams, and the motion passed.

Treasurer's Report: Treasurer Greg Wilson detailed the activity in our bank account, with deposits and checks written since December 31, 2021, and gave us the ending balance. After a motion and second to accept the report, the motion passed. Greg had only one bill from Print Pros to present, Wayne Moore presented a motion to pay, with a second from Chuck Grabowsky, and this also passed.

Visitors, Sunshine and Sorrow: Former member Dick Smith had had an accident. John Giuliano had a partial foot amputation; but he is able to get around.

Short Tour Report: David Frazee brought up our planned lunch tour, scheduled for Monday, February 14th. Members will meet at the Clubhouse at 11 a.m. and then drive to the Curbside Café in Vista (307 Main Street). This new format of a lunch tour will replace our monthly Break-

fast Meetings.

Long Tour Report: Bruce Howe was not at the meeting, but plans for the CCRG in Paso Robles, scheduled for April 4-7, were discussed. Presently, we will leave Sunday, April 3 and tour the US Navy Seabee Museum in Port Hueneme. The CCRG information is on the MAFCA site, and you should make reservations if you plan to go. We also talked about the Orange County Pancake Breakfast plans, as the date was finally given out as Sunday, March 20. As we were now talking about long tours, Greg brought up donations to the meets we attend. We had motions and voted on: two \$50 donations to each CCRG and Pancake Breakfast tours, and \$100 each to the Seabee Museum and to Dan Murphy Museum.

So Cal Report: No SoCal report given.

Vice President's Report: Mark Greenlee had Palomar A's hats and t-shirts available.

Reflector Director's Report: David Frazee discussed how many members received the Reflector by email, and how many still received the mailing. If we can reduce the number of copies needed for mailing, he could do the printing at home. We decided to add a memo for three months to the mailed copies to see if it would be possible to change to an email for any members, and then they would do their own at-home printing.

Membership: Lisa Frazee was not in attendance.

Tech Director: For this month's Tech Report, David brought in a tool he found

in his father's garage. He showed it to the members and asked who might know what it is. It turned out to be a multi-meter W169 wrench. Chuck will give a tech report on starter motors at the next meeting.

Web Master: Sheila Saxman was not in attendance.

Public Relations: Barbara Kruegel told us we were published, and is having good luck with the San Diego Union Tribune.

Correspondence: No correspondence this month.

Old Business: None.

New Business: Greg suggested that we invite new members to any long tours, specifically the upcoming Orange County Pancake Breakfast, as so many Model A's are there to look at and it is a very enthusiastic, fun event.

Hospitality: Anthony thanked members who brought refreshments to tonight's meeting. For next month's meeting, Ed Simpson, Mark Greenlee, and David Frazee have volunteered.

Monkey Business/Show and Tell: Anthony Lugo brought up how very expensive tickets are for the Super Bowl in Inglewood, & reminisced about learning to drive in that area.

Raffle: Jon & Anna Velasco conducted the raffle. Anthony Lugo won the Attendance Prize, Nancy Quinlan won the Birthday Prize, & the 50/50 was won by Barbara Kruegel.

Adjournment: There being no further business, the meeting adjourned at 8:12 p.m.

Respectfully submitted by Linda Thamer,
Secretary

Tour to Curbside Swami's



Six Model A's and sixteen members and friends headed over to Vista to enjoy lunch and show off their cars.

We drove off aimed to arrive at the Curbside Café, but Greg Wilson, our advance scout, redirected us to the nearby Swami's due to the overflow crowd at Curbside. We understand that three members found seats at Curbside, and apologize for the change in plans.

The short drive was going very well when the leader's truck (David Frazee's) simply stopped. Finding a loose wire, he plugged it in, pushed the starter again, and away we went; for a half mile when it stopped once more. Finding another loose wire, he plugged that one in too, pushed the starter and again, away we went; for another half mile until it died. Waving the rest towards the restaurant, he lifted the hood, and found all of the wires tight this time. It seems that the truck simply wanted him to diet.

Five minutes later, though, he started it again and hasn't had a problem in 30 miles since.

Long Tours for 2022

MARCH 19-20 ORANGE COUNTY PANCAKE BREAKFAST. The overnight group will leave the Hwy76/I-15 Park and Ride at 9:00 AM on Saturday, March 19th and stay overnight in Orange returning home on Sunday after the Breakfast



APRIL 3-8 CCRG JAMBOREE PASO ROBLES We will depart from the Hwy76/I-15 Park and Ride at 9:00 AM on Sunday April 3rd traveling to Port Hueneme. Monday morning, we will tour the Seabee Museum in Port Hueneme, and then on to Paso Robles and the Jamboree. We will leave Paso Robles on April 7th and spend the night in Tehachapi. We return home on Friday, April 8th. As of now the planned Auto Museum tours are on hold due to Covid closure, but Clyde is attempting to arrange one.

APRIL 29-30 SPRING OPENER CLEAR LAKE This event has been **CANCELLED** due to Covid

MAY 7 ANTIQUE TRUCK SHOW- ORANGE EMPIRE RAILWAY MUSEUM- PERRIS This will be a day trip. There will be several hundred trucks of all vintages, a swap meet, and vintage train rides are available



JUNE 12-17 MAFCA NATIONAL CONVENTION KERRVILLE, TX Jeanette and I will be attending, but will be trailering back early to pick up Ruby, our Deluxe Delivery which is being restored prior to the meet and visit relatives. The Texas Hill Country is beautiful and was the location for a previous National Tour. John Lavoy, a MAFCA Director, and publisher of the *Model A Times* has led several tours and is planning to lead one from California back to the Convention. His tours include all the planning and reservations, and typically have a trouble trailer.

SEPT 11 19TH ANNUAL ALL FORD CAR SHOW AND SWAP MEET- ORCUTT, CA A nice show and Old Town Orcutt has a lot of shops and restaurants. This will probably be at least a three days and be 500 miles round trip.

Understanding the Ford Viscosity Cup

The Ford viscosity cup is a simple gravity device of 100 ml that permits the timed flow of a known volume of liquid passing through an orifice located at the bottom. It is generally used for determination of viscosity of Newtonian paints, varnishes, lacquers, and can be used for related liquids such as water and thin motor oils. It is not generally used for determination of non-Newtonian liquids such as blood, shampoo and water-based paints.

A good example of a non-Newtonian liquid is ketchup as it becomes runnier when shaken - so be cautious shaking the bottle, or you'll have "hamburger soup."

To run the test on paints, the Ford viscosity cup shown in Fig. 2.25 is filled with the liquid under test up to the top level and the time for the liquid to flow through one of the five standard orifices is measured. Based on the orifice size, five Ford viscosity cup viscometers are available: Nos. 1, 2, 3, 4, and 5. The larger the number, the more viscous the liquid. In other words, it's "thicker."

Measurement of viscosity is carried out at $25 \pm 0.2^\circ\text{C}$ ($77 \pm 0.4^\circ\text{F}$). The choice of cup depends on the efflux time anticipated (time till empty) and Fig 2.26 may be used as a preliminary guide for this choice.

The viscosity grade of a lube oil is determined by the Society of Automotive Engineers (SAE). Oils can be separated into multigrade oils and monograde oils. Multi-

Table 2-16. Standard oils for calibration of Ford viscosity cups.

Cup Number	Approximate Cup Viscosity Range, cSt	Standard Oil Designation for Calibration	Approximate Kinematic Viscosity Designated at 25° C, cSt
1	10—35	S-10	20
2	25—120	S-20	35
3	49—220	S-60	120
4	70—370	S-60	120
5	200—1200	S-200	460

grade oils must fulfill two viscosity specifications, their viscosity grade consists of two numbers, e.g. 10W-40: 10W refers to the low-temperature viscosity ("Winter"),

40 refers to the high-temperature viscosity. The SAE generally measures at 100° C, however, and an example of an SAE 30W motor oil at 100° C would have a viscosity of 9.5 centistokes (cSt).

Ford viscosity cups are generally no longer used to measure motor oil. Instead oil is measured with a Hoppler method falling ball viscometer such as the Rheotest example shown below for sale for \$ 3,669. Still, you can buy a plastic Ford cup for under \$10.

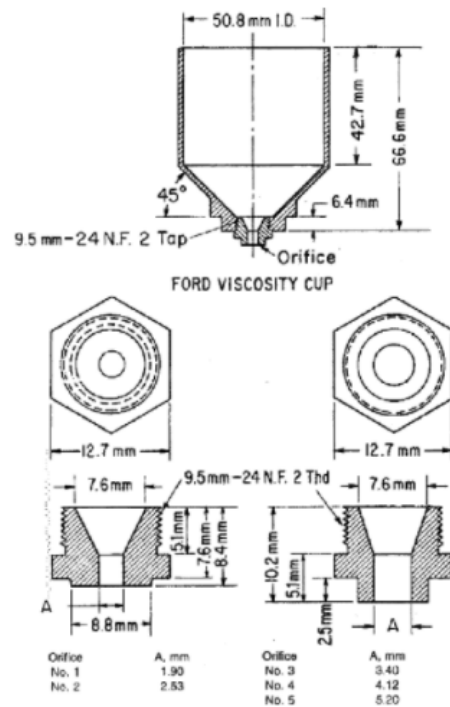

Ford Viscometer specifications



Club Considerations

This is a pivotal year for the Palomar Model A Ford Club. When the club was founded, El Camino Real between Oceanside and Del Mar was mostly a two lane rural road, parts of which were used as a drag strip for high school guys with hot rodded Model A's.

Now, as these same Model A owners reach their late seventies, there's hardly a stretch of the old highway a quarter of a mile in length that doesn't have a stoplight, and isn't filled with six lanes of slow moving traffic on a Saturday. The time has come to stop burning rubber and racing for pinks.

Other changes for consideration include:

- If you receive *The Reflector* electronically, and also in the mail, **please contact the editor and confirm that you want to continue with the snail mail version** as it is costly to the club. (Over \$25 per year and that's not including the editor's time and gas used which is donated.)
- Having tours to restaurants for lunch, only meeting at the Park to travel together so we aren't alone if there are mechanical problems. The alternative would be for someone to **volunteer to lead tours** for sightseeing and to show off our fabulous collectors cars in addition to getting food.
- Encourage attendance at our Christmas Party by raising our dues slightly, and **subsidizing lunch** by more than that amount for those who attend.
- Set aside **an entertainment budget** to make our meetings more fun and increase attendance.

Golden Trophy Stands Guard on Hollywood

The most familiar golden item in March is the 8.5 lb golden statue of a naked knight and his sword providing discretion, standing on a film reel with five circular spokes representing each of the original branches of the academy: actors, directors, producers, technicians, and writers.

Today there are 23 categories and 17 branches who make up the Academy of Motion Pictures—There should be 18, but the Academy has refused to admit stuntmen and women every year since first petitioned in 1991. (I guess they didn't want to cast a special statue with its arm in a sling?). They didn't update the statue to have 17 spokes.

The trophy has always come without a name plate; one method to assure the secrecy of the academy's picks before presenters pull them from the envelope. From 1930 to 1940, the Academy sent the winner's names in the mail to newspapers to publicize their efforts and asked the editors not to reveal the winners until after 11 PM, the night of the ceremony, but in 1940, *The Los Angeles Times* published the names in an edition coming out before it even started. Since then, they have famously announced that the names are held in a single sealed envelope.

Until 2010, the winners had the option to give the trophies back to have their names engraved; sometimes, not to be returned for weeks. Since 2011 a nameplate has been pre-engraved for every nominee, and it's only at the Governors Ball—the super swanky party that follows



the ceremony—that the winners can get them attached to their statue.

The academy was only founded Jan 11, 1927, 26 months before the first awards ceremony. Louis B. Mayer spearheaded the effort because he wanted to avoid the unionization happening worldwide, and have a group to mediate for labor-management disputes and negotiations, and improve Hollywood's image after the Fatty Arbuckle debacle brought eight states to found censorship boards.

It's ironic then that the token chosen for recognizing Academy members is a fighter who is both gold and naked.

March Lunch Tour to Fat Ivor's in Valley Center

2022 Member Hdbk Complete

Lunch Tour Date: March 14
Time: 10:00 @ Palomar Estates

Expected Arrival: 11:00

Location: Fat Ivor's,
27961 Valley Center Rd, Valley Center



The Tail of the restaurant:

Ivor "Tommy" Thomas served 20 years in the Marine Corp and retired in 1971. With wife Georgine at his side, they moved to Valley Center, and in 1981 purchased Zuke's Pizza located at the present sight of Fat Ivor's. After unsuccessful attempt at the perfect pizza, Tommy decided to change the menu to Texas style BBQ. Tommy being a heavy set man and blessed with rather odd name decided to call his venture "Fat Ivor's Rib Rack". He always lived by his motto.

"NOT AS MEAN, NOT AS LEAN, BUT STILL A MARINE"

It didn't take long for Tommy's dream to take off. Offering all you can eat oak-smoked beef ribs for \$5.99, the restaurant was never empty again. He soon had to expand the menu to include NY Chicken

and Prime cuts of beef to meet the needs of his growing clientele. The All You Can Eat offer, on the menu, reads to only available all day on Weekends and costs \$18, on the website, it says to be all open hours. Yes, they do have salads and sandwiches, too.

Fat Ivor's success was shared by the youth of Valley Center as well as the V.C. Optimist Club. Tommy never turned down a local kid needing a few extra bucks to get through a semester of school or season of sports.

Tommy passed away in December 2002 after 21 years of turning out the best BBQ in Southern California. The following February, the restaurant burned to the ground leaving Georgine with a decision to rebuild or enjoy early retirement. After much coaxing from the community, she decided to bring the Fat Ivor's back to life. During the 2 years and 11 days it took to rebuild, Georgine and her investors resurrected the BBQed phoenix.



This might a good time for you to volunteer to be this year's Membership Chair. As you can see by the photo, the Member Handbook has been finished. Volunteer now, and you'll have a full year to learn the ropes, or to design alterations you may want to improve next year's Handbook.

I've wanted snippets of biographical information added to the Handbook. For instance, what is or was their career? Did the car owner restore it themselves or buy it already restored? Which of the last five years have they driven their Model A's more than 500 miles?

If you also would like that sort of additional information in the Handbook, this is the best week to step into the job.



ARIZONA MODEL A

15838 South Gilbert Road Chandler, Arizona 85225 (480)782-0266

Business Hours:

Tuesday - Friday: 9am - 12pm 1pm - 5pm	. New Parts . Used Parts . Service . Restoration
Saturday & Evenings: Appointment Only!	Owner: Sam Guthrie

FUTURE ENGINE REBUILDER AD



RANCHO BERNARDO
Print Pros
YOUR PRINT AND COPY CENTER

Mike Griffin
Owner

858-675-0770
fax 858-675-0775
mikeg@rbprintpros.com
www.rbprintpros.com

11407 West Bernardo Court
San Diego, California 92127



SERSHA BEARS BY SERIETA

SAN MARCOS, CALIFORNIA 92078

SERIETA HARRELL
Handmade Teddy Bears and other Cuddly Critters
760-597-1858
sershabeats@yahoo.com



MITCHELL MANUFACTURING

Steve & Cyndi Mitchell
Mitchell MFG.
530-458-4500 800-859-2088
www.mitchelloverdrivemfg.com



MODEL A FORD
SYNCHRONIZED-TRANSMISSION FORD OVERDRIVES/UNDERDRIVES
VINTAGE CAR OVERDRIVES 1928-1948

P.O. Box 925 1157 Parker St. Colusa, CA 95932

Bill Hansen

Model A Ford Service & Repair

Proudly using KR Wilson Tools for

Dealership Quality

Day 760-789-8296
Evening 619-461-1001
lamesla@yahoo.com

14755 Mussey Grade Road
Ramona, CA 92065

America's Finest City Dixieland Jazz Society



BILL ADAMS
President
(760) 809-4793
badamsavc@yahoo.com

P.O. Box 880387 🎵 San Diego, CA 92168-0387
Phone: (619) 297-5277
www.sdjazzfest.org 🎵 jazzinfo@sdjazzfest.org

FUTURE POWDER COATING PAINTER AD

Complete Rebuilding of: Engine, Transmission, Clutch, Rear end, Front end, Steering Box & Brakes. **Other Services:** Wheel Balancing, Counter Balanced Crank Shafts, Engine Babbiting, Lightened Fly-Wheels, V8 Clutches, Leakless Water Pumps, Carburetors, Distributors, Generators, Starters and More.

CALL FOR COMPLETE LIST OF SERVICES!

MARCH 2022

Sunday	Monday	Tuesday	Wednesday	Thursday	Friday	Saturday
		1 MA Morrison	2 Club Meeting at 7 PM	3	4	5
6	7	8	9	10	11	12
13	14 Peggy Williams Lunch Tour to Fat Ivor's meet at P. E. at 10:30	15	16	17 Jeanette Smith	18	19 Tour to Orange for Pancake Breakfast
20 Mark Greenlee David ♥ Karyn Frazee Pancake Breakfast in Hart Park, 8:00 AM. Orange	21 Jim ♥ Nancy Quinlan	22 Linda Thamer	23 Jim Gasparo	24	25 Louise Greenlee	26 Betty Stonebreaker
27 97th Annual Academy Awards	28	29	30	31		CCRG Tour Sunday April 3rd

2022 Palomar Model A Ford Club Board:

President 760-439-9103
Ed Simpson
Vice President 760-731-2501
Mark Greenlee
Treasurer 760-525-8993
Greg Wilson
Secretary 760-586-6554
Linda Thamer
Long Tour Dir. 858-692-4309
Bruce Howe
Short Tour Dir. 760-822-9523
Committee
Reflector Editor 760-822-9523
David Frazee
Public Relations 619-981-6523
Barbara Kruegel
Hospitality 760-650-5333
Donna & Anthony Lugo
Membership 760-729-4865
Vacant
Raffle Chair 760-798-4642
Jon & Anna Velasco
Librarians 949-492-4255
John & Judy Burrell
Tech. Director 760-439-9103
Committee
Web Master 951-696-0323
Sheila Saxman

PALOMAR MODEL A CLUB

North San Diego County
2410 Appian Rd
Carlsbad, CA 92010
Phone: 760-729-4865
Email: frazeelntree@hotmail.com



The Palomar A's Club was founded in 1960 as a MARC affiliate, and elected Henry Jenkins as its first president for 1961. In 1963 it became a chapter of the Model A Ford Club of America, 250 South Cypress, La Habra CA 90631. Members of the club are encouraged to also join the national organization. Member registration and dues payment for MAFCA is available on www.MAFCA.dfm Palomar dues are \$20 per year



General meetings are held the first Wednesday of each month at the Palomar Estates East Clubhouse: 650 S Rancho Santa Fe Rd, San Marcos, CA. The doors open at 6:30 pm for social time and the meeting starts at 7:00pm. All Model A hobbyists are welcome to attend. Tours, shows, seminars, and social events are regularly scheduled throughout the year.

The Reflector is published in Escondido, CA after the 20th of each month with item deadlines on the 15th. For questions or to advertise on **The Reflector**, contact the editor, David Frazee at frazeelntree@hotmail.com

February, 2022

The Reflector

PLEASE
PLACE
STAMP
HERE

