

# Rapidly Expanding Chain of Restaurants Reaches Ohio

**F**ord's Garage is more than just a neighborhood burger and beer joint, it gives customer's the feeling of being on a Hollywood movie set or within a 1920's service station. Decorations include vintage Ford vehicles, gas pumps, and fixtures. Their bars feature prohibition-style elements of old brick, rich wood, and a hand-hammered copper bar top.

The original location opened in 2012 in historic downtown Fort Myers, less than a mile from [Henry Ford's winter residence](#) and it's quickly expanded to twenty locations, interesting potential franchisees with an average store volume of over five million dollars.

The twentieth location, which opened just this month, is in part of the old Le Blond Machine Tool Co. plant in Norwood, Ohio, just outside of Cincinnati.

[Richard Knight Le Blond](#), founded the company in 1887 to manufacture metal lathes but also spindle drills and other milling machines. The Norwood facility was built in 1917, designed by the Cincinnati firm of Zettel and Rapp. It exemplified the "factory beautiful" school of industrial design. Designers took advantage of natural lighting, in addition to installing state-of-the-art electric lighting. Workers' locker rooms were equipped with showers and modern washrooms. Other amenities included an employee dining hall, an infirmary and a coffee-service area. The outside grounds resembled a park, complete with a lake, fountain, stone bridge and pavilion.

The restaurant has a collection of four Model A's, a '29 roadster, and '31 Victoria, SW Fordor, and steel topped AA. They even have an [online store](#) to buy trade-marked clothing and accessories including a "craft milk" onesie for your infant and a bandana collar for your dog.



Where now you can get a tower of onion rings on an old funnel, you sit under the stack of factory powerhouse..



## CONTENTS

- NEW RESTAURANT [PAGE 1](#)
- ED'S MESSAGE [PAGE 2](#)
- MAY MINUTES [PAGE 3](#)
- MODEL A YOUTH MONTH [PAGE 3](#)
- MAY TOUR TO MAMA N' PAPA'S [PAGE 4](#)
- JUNE LUNCH TOUR TO FALLBROOK RIB SHACK [PAGE 4](#)
- GREASE FITTING [PAGE 5](#)
- NEW MEMBER [PAGE 5](#)
- PERRIS TRUCK SHOW [PAGE 6](#)
- GIRL'S PURSES [PAGE 7](#)
- BLUE PLATE SPECIAL [PAGE 8](#)
- ADVERTISERS [PAGE 8](#)
- JUNE CALENDAR [PAGE 9](#)



In 1927 LeBlond bailed out the bankrupt Schacht Truck company, taking over financial control, and in 1936, the [Ahrens-Fox Fire Engine Company](#), all of Cincinnati.

# The Message from President Ed



**M**ay's meeting was cancelled at the last moment as asbestos was found in the clubhouse during renovation. I called some members and the rest got emails. Hope there were not screw ups. We used to have a phone tree alert system, maybe it should be restored? Did everyone get the word?

Prior to leaving on last week's Monday lunch tour, I surveyed the clubhouse project. It looks like a major interior paint job is in progress. A posted notice said that all should be completed by May 24. We should be good to go again come June.

May's lunch tour was fun for all. There were three Model A's on the way to lunch visiting

Heritage Park in old San Marcos. All the restored buildings were closed that day, but we enjoyed a good look-see all around, and, as always, our cars generated many curious inquiries. More members joined us for lunch and lively conversation followed. I counted ten in our group.

This coming meeting ought to be good as we await stories from the last long tour. David Frazee has the floor this time for a techno-puzzler for us all.

Meanwhile, back at the chicken ranch...

Both Model A trucks rested in silence. All my thoughts centered around the coveted driver's license that became such a right of passage for a sixteen-year-old.

The family car at that time was a 1951 four-door, sea-foam green Studebaker Champion. It had a gutless six-cylinder motor and a "slush-box" hydromatic transmission. It was hard for me to dream of much fun in that car.

San Bernardino was a cool, car town, and the Studebaker was a sure "dog" for a driver. In retrospect, I think it was a good premeditated parental move to save that Studebaker and keep their son's hot-footed ambitions damped down.

My fantasies festered. I was always good at scrounging up stuff. Over time I scoured nice, chrome windshield frame, a dual carb "log" manifold (six bucks), a 32 Ford front bumper, and a set of spin-

ner hubcaps off an Oldsmobile.

I my head, my dream wagon was damn near drivable..

Well, life goes on, I made it through high school, then on for more studies. I kinda forgot about the Model A's. One day the scrap metal man made a pass thru town, the price of iron was up, and my dad cut a deal. The roadster pickup left our place, reconfigured in dimensions alone with lots of other rusty metal off the ranch, loaded up on the bed of his flat bed truck. The 'new' Model A pickup languished in the feed house and finally sold, I think for \$150.00... stay tuned.

Ed Simpson.



David Hasselhoff with a 1951 sea-foam green fordor Studebaker Champion.

# Minutes of the Cancelled May Meeting

## May is Model A Youth Month

**Call To Order:** President Ed Simpson was not in attendance, as the meeting room at Palomar Estates East was closed for remodeling, but the meeting was called to order promptly at 7:00 p.m. sharp anyway.

**Minutes:** Linda Thamer was not in attendance, but she was well aware that we did not have a quorum of members.

**Treasurer's Report:** Greg Wilson was not in attendance.

**Visitors, Sunshine and Sorrow:** There were no visitors.

**Short Tour Report:** David Frazee was not in attendance. Lunch in June will be held at the Fallbrook Ribshack at 76 and I-15 on June 13th.

**Long Tour Report:** Bruce Howe was not in attendance.

**So Cal Report:** There was not a SoCal meeting.

**Vice President's Report:** Mark Greenlee was not in attendance.

**Reflector Director's Report:** David Frazee was not in attendance.

**Membership:** The Membership Chairperson might have attended, but no one else was able to verify that.

**Tech Director:** Echoes of former tech talks were heard throughout the darkened meeting room.

**Web Master:** Sheila Saxman was not in attendance.

**Public Relations:** Barbara Kruegel was not in attendance.

**Correspondence:** No correspondence this month.

**Old Business:** It was decided to table old business until the June meeting.

**New Business:** No new business.

**Hospitality:** Anthony and Donna Lugo were not in attendance, however, they wished to convey their gratitude for those members who brought refreshments to tonight's meeting.

**Monkey Business/Show and Tell:** No one was able to identify the mystery tool that David Frazee brought to the meeting. It was suggested that he bring it back at the next meeting on Wednesday, June 1st, when Clyde Marion would no doubt identify the tool within ten seconds.

**Raffle:** Jon and Anna Velasco were not in attendance.

**Adjournment:** There being no further business, the meeting adjourned at 7:01 p.m.

*Humorously submitted by David Frazee, Reflector Editor*



I would like to remind you that we have proclaimed May as Model A Youth month. We have joined forces with the Model A Youth Restoration Award and the Model A Youth Scholarship organization. Check out our website for more

information on these fine organizations. I would like to ask each chapter and group to actively promote the hobby with our young people. Our chapter is hosting a BBQ at a members ranch where we will have a variety of Model A's on display. We have invited everyone to bring their children and grandchildren. There will be opportunities to check out the cars and honk the horns. Those with drivers licenses will take the wheel and develop their driving skills. If we provide memorable experiences, these young people will develop a love for the Model A just like we enjoy. Remember we have the A World Magazine available for the children. You can subscribe by sending your email address to [Aworld@mafca.com](mailto:Aworld@mafca.com). This is a wonderful electronic publication written by our editor, Sherry Winkinhofer. I hope you can do your part to share your car with grandchildren and neighbors.

Happy Motoring, Jay McCord

## June Lunch Tour: Fallbrook Rib Shack



**L**unch Tour Date: June 13  
Time: 10:00 @ Palomar Estates

Expected Arrival: 11:00

Location: Fallbrook Rib Shack

3235 Old Hwy 395, Fallbrook, CA

Phone: (760) 731-9133

The plan is to start out on some of the same roads as last month, but this time continue until we get to Old 395 and head north making a stop at [Waterwise Botanicals](#), which seems like most nurseries except for its large size and collection. For example, they carry 20 species of drought tolerant grasses. Home Depot online in comparison shows 51, but includes a variety of the same plant in different sized pots, Flax and English Ivy., and each is only available by ordering them online.

After the short stop, we'll travel on to the Rib Shack, located quite near to Nussy Burgers. and enjoy our choice of several sandwiches, roast meats, and comforting sides. No doubt, everyone will find something to enjoy at each stop.

## Local Tour to Mama n Papa's Pizzeria



**M**ay's lunch tour was fun, but sparsely attended partially due to the last minute cancelation of the May club meeting and the promotion of the food and tour beforehand.

As it turns out, coincidentally, all three drivers had trucks and facial hair. It may sound silly, but maybe to get bigger turn outs, we'll need to sneak into member's homes and hide their razors.

One thing also, was that my truck didn't have any problems whatsoever. I'm beginning to think it's a drama queen and only acts up in front of a large audience. Maybe if I painted it a much brighter color, something that would make it stand out, mechanically it would run like a Swiss watch.

So anyway, we had a lot of fun. We more

than doubled our number when we arrived. Our waitress shared in our good times, and the food was also delicious. I, and a few others, admitted that we hadn't been to *Mama 'n Papa's* for several years, but I suspect we will all make a return visit a lot sooner now that we've been reminded of what we've been missing all this time.

David Frazier



# Grease Fitting Added to 7 Tooth Steering Gear

The drilled hole in the steering sector shaft, through which the lubricant in the steering gear housing was carried to the sector shaft bushings, has now been discontinued. Sector shaft bushings are now lubricated by means of a lubricator fitting placed in the steering gear housing. (See A, Fig 570) Lubricant should be forced into this fitting every 2,000 miles.

Should an instance arise where it is necessary to install the present design sector in an old steering gear assembly, it will be necessary to install a lubricator fitting in the housing. This is done by drilling a 21/64" hole 2-3/32" back from the center line of flange where housing is bolted to frame. (See Fig 571) The hole should be drilled through housing and sector bushing and then tapped with a standard 1/8" pipe tap. When tapping the hole do not tap too deep. The hole should be tapped just deep enough so that when the lubricator fitting is screwed down tightly approximately two threads on the fitting will remain above the surface of the housing. (See Fig 571)

You fill the steering gear box with the very heavy and thick 600W oil and you squirt a little grease into this fitting that you are adding. The grease will lubricate the sector shaft and it will form a little bit of a barrier that will slow down (not stop) the 600W gear oil from seeping out the sector shaft.

Jim Cannon's Tech Tips

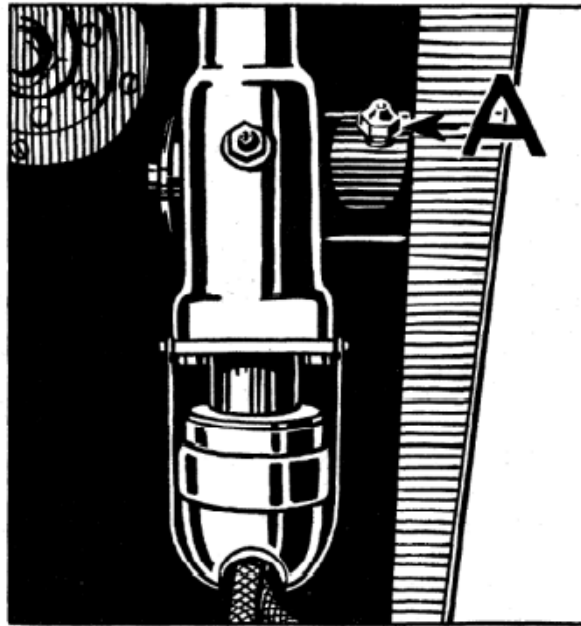

Fig. 570

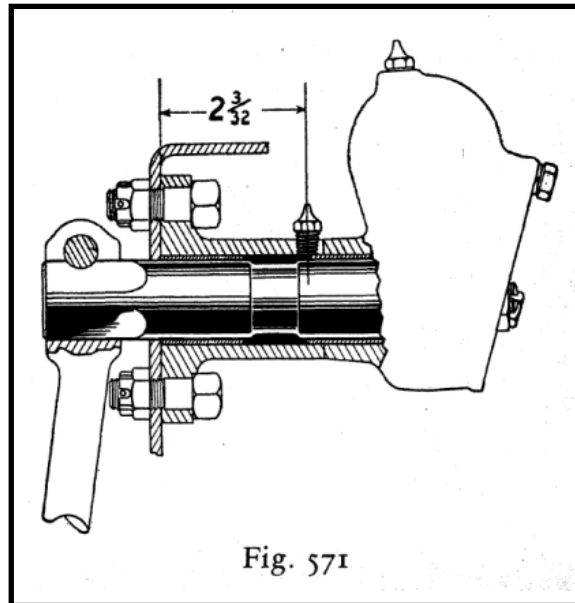

Fig. 571

# New Member

**R**ick Spinello

2221 Rainbow Road

Fallbrook, CA 92028

Home Phone: 760-703-0965

Email: RickSpinello@gmail.com

Birthday: May 30

Owens a 1930 Model A Chassis in progress

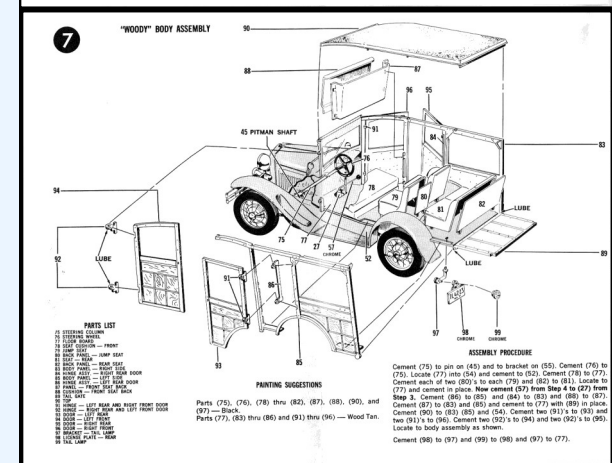
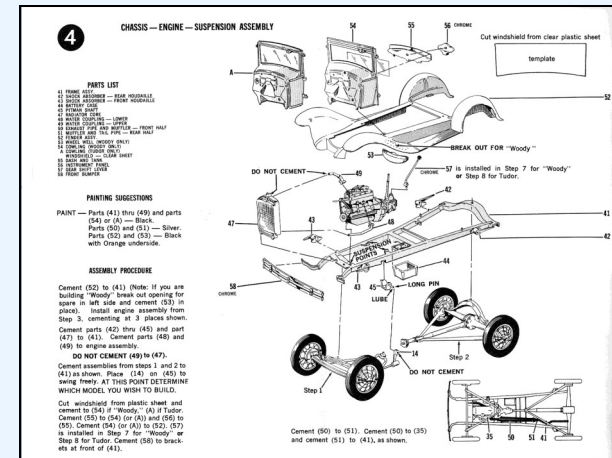

Plans for building a Revell 1931 Woody model.

# Perris Truck Show



Best of Show, Light Duty 1949 Diamond T owned by Michael McQueen *Old Iron Express Newsletter*

Five members in three Model A's attended the 37th Annual ANTIQUE TRUCK SHOW at the Southern California Railway Museum in Perris on Saturday May 7th. For some unknown reason no ladies chose to attend. Attendees were Howard Kruegel, Fred Slikker, Clyde Marion, Joe Williams, and Bruce Howe. It was about an 80 mile roundtrip mostly on the freeway. Coming home we had some heavy stop and go traffic on Hwy 215.

There were trucks of all varieties, sizes, and ages, and even a couple of Model As. There was also a Model AA Truck converted to a rail car from the Narrow Gauge Railroad Museum. The Railway Museum is worth the visit and has many interesting trains and exhibits to view, and train and trolley rides are available. The Fred Harvey Museum was open with a couple of very knowledgeable docents

on hand. Fred Harvey (Harvey Girls) had restaurants and hotels all along the railroads with many in National Parks. (See article on Blue Plate Special on [page 8](#))

There was a swap meet and Howard claims this was the first swap meet he had ever been to where he did not buy something. He seemed to be feeling okay, and most of the items were truck related.

We looked for the closest restaurant for lunch and ended up at the [Bombshelter Restaurant](#) at Skydive Perris. I assumed from seeing occasional parachutes in the air driving by on the freeway it was a small center somewhat like the Oceanside airport. Skydive Perris is one of the largest skydiving centers in the



Best Display of Rust, 1948 Diamond T Tanker owned by Tom Reim *Old Iron Express Newsletter*



world and a major facility. Several hundred people were there, planes were taking off every few minutes, and people were jumping out of perfectly good airplanes.

It was an enjoyable day and an opportunity to observe other peoples hobbies of old trucks, railroads, and skydivers.

Bruce Howe

# Children's Accessories—Purses

I originally wanted to find advertisements for little girl's purses. They're adorable. Especially when you find out what treasures they're carrying, like rocks, Legos, and a sock; and so you look down and see that they have one sock on and one sock off.

Sadly, the earliest advertisement I found was in the *LA Evening Citizen* just before Thanksgiving, 1945, for the "[Margaret O'Brien Collection](#)" at the *Broadway* just in time for Christmas shoppers.

Earlier than that, I only found the oft repeated quote, "The sweetest thing in purses is when a pretty girl purses her lips." (Maybe "Girl Handbags" is what I wanted to search?).

Anyway, I figured that none of my own family would have bought a designer handbag for an aunt when they were



girls in 1931; they wouldn't have had the money. What they might have done was to use a flour sack to make a drawstring clutch.

So, I was in luck finding examples of both a tiny version of an adult's purse and an ad for a book which includes a pattern for using flour sacks to make a child's purse.

[Bluebird Flour](#) still sells flour in linen sacks. You can order it on Amazon. If you use the flour to make cookies, the sweetest thing in purses won't be lips.

IT IS AMAZING WHAT CAN BE MADE FROM MAPLE LEAF FLOUR BAGS

**Smart Clothes for the Family**  
**Smart Things for the Home**  
... and they can be made Easily and Quickly

With the aid of the suggestions in the free book "Smart Sewing Suggestions", every trace of printing on the bags can be removed in seven minutes, leaving the useful even-weave fabric ready for use.

Just a few of the things you can make from MAPLE LEAF FLOUR BAGS as shown in "Smart Sewing Suggestions":  
Regulating dresses for little girls.  
Tremendous suits for little boys.  
Just-right tops for the Juniors.  
Snappy sport clothes for men and women.  
Tidy tailored dresses—so smart as they are economical.  
True beaming dresses and house dresses.  
Good-looking shirts for boy and man.  
Bags for hairdressing, sewing, shopping—the art-craft kind.  
Charming things for re-decorating the bedroom—curtains, spread, chair covers—and the newest manner.  
Livingroom accessories you'll love to own.  
Glorious embroidered pictures to frame for your walls.  
Slip-covers for you can pipe with color if you like.  
Candlewick designs of startling beauty.  
New ideas for patchwork triumphs.  
Cocoonet designs for table covers, spreads, pillow-slip trim and so on and so on.  
Frets, flowers, leaves, dogs, cats, rabbits, elephants, ships, toy-cars and many other things for embroidery or applique to all manner of reversible and furnishings.  
Look in "Smart Sewing Suggestions" for Patterns you buy for a fraction of their worth!  
Designs and instructions that need no pattern!  
Inspiration and help that will enable you to make beautiful things easily, reversibly, and with no cost for your main materials.  
Each Pattern tells how many bags are required

LOVELY DESIGNS for Embroidery and Applique for use on just everything Only 10c. POST PAID

ART EMBROIDERY AND APPLIQUE  
Made Easy with the Service we offer  
Our transfer sheet gives you (1) Transfers for embroidery and applique designs that you can use in countless ways—making decorations for the little folk's clothes, crib covers, etc.; gay modern personal touches for the junior's possessions; dignified designs to apply to unusual and artistic housefurnishings. In our free book, "Smart Sewing Suggestions", you'll find ideas galore for the use of these designs; also additional embroidery and applique designs for which you can get our special patterns at their amazingly low price. (2) Your initial in a big variety of styles and sizes. (3) Full instructions for using them.

# Touring Coupe For Sale

After many years of enjoyment it's time to pass our 1930 Model A Coupe along to someone else. We are asking a discounted \$16,900.00 CASH to anyone either in or referred thru the club.

This is a great touring car as it has a touring engine and a 4 speed syncro tranny plus many extra features for touring like a top end CB. Custom interior with a dash that includes a tachometer, vacuum gage, temp. gage turn indicator lights, and alternator indicator light, electronic ignition, high compression head, 12v system w/ separate circuit breakers for each system, restored in 2010, new roof wood and rubber top, repainted with 2 part epoxy paint, and boxes & boxes of extra parts and manuals.

If interested contact us thru e-mail [davarb55@gmail.com](mailto:davarb55@gmail.com) or phone 760-913-5184. Dave & Arlene Belt



## Blue Plate Special

If you look up the origin of the term *Blue Plate Special*, you will undoubtedly find it attributed to a menu for the Atchison, Topeka and Santa Fe railroad restaurants, operated by Fred Harvey. It has even been “established” as being first printed on October 22, 1892 by Daniel Rogov.

That might be true, however, it appears very unlikely that the words used were intended at that time to identify a low-cost menu choice offered because the chef had plans to cook a large amount of that one item that day. Instead, as all of Fred Harvey’s dishes were white with a blue chain pattern around the rims, and railroad car menus of 1892 did not have prices allowing diners to compare for value, if meals were referred to as a “blue plate special” it would have referred to absolutely everything which Fred Harvey offered.

The term as we understand it appears to come from roadside cafes springing up alongside the budding highway systems of the early 1920’s in which, you might not recognize the best offerings at each restaurant, but you could recognize what each considered their best value. I theorize that rather than Fred Harvey—where everything was on an actual blue plate—the color blue was chosen because in the US, blue was the color distinguishing first place in county fairs. (Red was the color in Canada and the UK.)

In order to make this blue story fit with the golden theme for this anniversary volume of *The Reflector*, Fred Harvey’s blue plates would have been served of the **Golden Gate Ltd.**: The passenger train between Oakland and Bakersfield on the ATSF, which, with the



**ARIZONA MODEL A**  
15838 South Gilbert Road Chandler, Arizona 85225 (480)782-0266

Business Hours:

Tuesday - Friday: 9am - 12pm 1pm - 5pm	. New Parts . Used Parts . Service . Restoration
Saturday & Evenings: Appointment Only!	Owner: Sam Guthrie



**HIGH SOCIETY NEW ORLEANS JAZZ BAND NIGHT OWLS**  
**SIERRA SEVEN CORNET CHOP SUEY**  
**GINO & THE LONE GUNMEN KATIE & THE LOST BOYS**  
**MAD HAT HUCKSTERS TITANIC JAZZ BAND**  
**UPTOWN RHYTHM MAKERS**  
**THE SAN DIEGO JAZZ FEST & SWING EXTRAVAGANZA**  
**NOV. 23-27 2022!**  
**DAVE BENNETT & SUE PALMER QUARTET & HER MOTEL SWING ORCH.**  
**CHERLY'S VINTAGE JAZZ MICHAEL GAMBLE'S RHYTHM SERENADERS**  
**SDJAZZFEST.ORG**

GRAND DOMINION JAZZ BAND  
CARL SONNY LEYLAND  
MISSION BAY HIGH SCHOOL PRESERVATIONISTS

addition of bus service, provided transport between San Francisco and Los Angeles between 1938 and 1968.



**SERSHA BEARS BY SERIETA**  
SAN MARCOS, CALIFORNIA 92078

**SERIETA HARRELL**  
Handmade Teddy Bears and other Cuddly Critters  
760-597-1858  
sershabeats@yahoo.com



**Mm MITCHELL MANUFACTURING**

**Steve & Cyndi Mitchell**  
**Mitchell MFG.**  
530-458-4500 800-859-2088  
www.mitchelloverdrivemfg.com

MODEL A FORD  
SYNCHRONIZED-TRANSMISSION FORD OVERDRIVES/UNDERDRIVES  
VINTAGE CAR OVERDRIVES 1928-1948

P.O. Box 925 1157 Parker St. Colusa, CA 95932

Santa Fe dining car service by Fred Harvey.

LUNCHEON, April 8

Radishes	Olives	Young onions
Soft shell crabs, remoulade		
Cucumbers		
Filet mignon a la Stanley		
Special fried chicken, farci		
Mashed potatoes	Spinach with egg	
New asparagus, hollandaise		
Cold ham	Cold ox tongue	
Cold boned turkey, en gelee		
Watercress salad		
Strawberry short cake, whipped cream		
Swiss cheese	Toasted crackers	
Coffee	Tea	

A Fred Harvey Dining Car Menu published April 8, 1909



# JUNE 2022

Sunday	Monday	Tuesday	Wednesday	Thursday	Friday	Saturday
			1 Judy Giuliano Club Meeting at 7 PM	2	3	4
5 Alyssa Morgosh Craig ♥ Barbara French	6 Dave ♥ Arlene Belt	7	8	9 George ♥ Judy Leitner	10	11
12 Kathy Marion	13 Lunch Tour to the Fallbrook Rib- shack meet at P. E. at 10:00	14	15	16 Anthony ♥ Donna Lugo	17 Nancy DiTo- maso	18
19 Joe ♥ Peggy Williams	20	21	22 Kyle Matthews	23 Pam Treserdern	24	25
26	27	28 ♥	29 JoAnn Cordtz	30		

**2022 Palomar Model A Ford Club Board:**

President 760-439-9103  
*Ed Simpson*  
Vice President 760-731-2501  
*Mark Greenlee*  
Treasurer 760-525-8993  
*Greg Wilson*  
Secretary 760-586-6554  
*Linda Thamer*  
Long Tour Dir. 858-692-4309  
*Bruce Howe*  
Short Tour Dir. 760-822-9523  
Committee  
Reflector Editor 760-822-9523  
*David Frazee*  
Public Relations 619-981-6523  
*Barbara Kruegel*  
Hospitality 760-650-5333  
*Donna & Anthony Lugo*  
Membership 760-729-4865  
Vacant  
Raffle Chair 760-798-4642  
*Jon & Anna Velasco*  
Librarians 949-492-4255  
*John & Judy Burrell*  
Tech. Director 760-439-9103  
Committee  
Web Master 951-696-0323  
*Sheila Saxman*

**PALOMAR MODEL A CLUB**  
North San Diego County  
2410 Appian Rd  
Carlsbad, CA 92010  
Phone: 760-729-4865  
Email: frazeelntree@hotmail.com



The Palomar A's Club was founded in 1960 as a MARC affiliate, and elected Henry Jenkins as its first president for 1961. In 1963 it became a chapter of the Model A Ford Club of America, 250 South Cypress, La Habra CA 90631. Members of the club are encouraged to also join the national organization. Member registration and dues payment for MAFCA is available on [www.MAFCA.dfm](http://www.MAFCA.dfm) Palomar dues are \$20 per year



**General meetings** are held the first Wednesday of each month at the Palomar Estates East Clubhouse: 650 S Rancho Santa Fe Rd, San Marcos, CA. The doors open at 6:30 pm for social time and the meeting starts at 7:00pm. All Model A hobbyists are welcome to attend. Tours, shows, seminars, and social events are regularly scheduled throughout the year.

**The Reflector** is published in Escondido, CA after the 20<sup>th</sup> of each month with item deadlines on the 15<sup>th</sup>. For questions or to advertise on **The Reflector**, contact the editor, David Frazee at [frazeelntree@hotmail.com](mailto:frazeelntree@hotmail.com)

2022 'June'

# The Reflector

PLEASE  
PLACE  
STAMP  
HERE

