

Reflections on the 50th Volume of the Reflector

It was such an honor to receive the Golden Bird award at the Christmas party amongst all of my family.

I hear you saying, “Doesn’t he mean friends and family?” No, I don’t. I’ve been with the Palomar A’s longer than I’ve been married. Longer than I was a librarian. Longer than I’ve been a driver... legally. And you folks have been there through thick and thin, so you are my family. Thank you for being there.

Sometimes I can’t believe it, but *The Reflector* has been a part of this club five years longer than I’ve been. Many of the first issues I remember arrived with that [sweet smell of elementary school mimeograph pages](#)—the fading blue colored ones.

The cover was the same black and white photocopied image of an AR 1928 Phaeton’s front, generally on goldenrod paper from 1972 through 1987. I was so fond of that, that I painted a mural of it on an inside wall of the family barn/car shed. I was able to buy the spray paint myself—as a teenager—talk about nostalgia.

In the 1980s and 90s, *The Reflector* was largely filled with typewritten pages from the board and other clubs, and newspaper clippings photocopied for members to enjoy. At some point, a very enterprising edi-

tor, hand-colored the covers of several issues. As the current editor, I’m glad that hasn’t become a regular practice. In four years, I’ve only hand-colored one or two issues: highlighting that it was time to renew your membership and A Christmas issue once when I had time to kill.



Fortunately for us editors, we shifted to email distribution and creating the issues in Microsoft Publisher back in 2011. That’s allowed us to do fancy things including providing “hot”

links to email addresses and web addresses. Us being Carla Hibbard, Dean Barnat, and myself. Carla’s work on *The Reflector* was exceptional and should have been recognized by MAFCA, but at least her editing of the SCRG’s *Regional Roundup* won [Best Regional Newsletter](#) twice.

I first made words and photos “hot” links in the tech talk articles back in 2018 in an effort to improve the experience for members receiving their copies by email. Clicking them, you could watch a video, get a larger copy of the image, or read a complete article of which I was only quoting a small part.

What’s Next for *The Reflector* [continued](#)

Vol. 50, No. 1

January 2022

CONTENTS

- ED’S MESSAGE [PAGE 2](#)
- CHRISTMAS PARTY [PAGE 3](#)
- REFLECTOR IMPROVEMENTS TO TRY [PAGE 4](#)
- THE MISSED TOUR [PAGE 4](#)
- LIGHT BULB’S 50TH [PAGE 5](#)
- LONG TOURS AND JANUARY CLUB EVENTS [PAGE 6](#)
- TECH TALK [PAGE 7](#)
- ADVERTISERS [PAGE 8](#)
- CALENDAR [PAGE 9](#)

MODEL A NEWS

[MAFCA HAS A NEW BOARD FOR 2022](#)

[MAFCA PRESIDENT, JAY McCORD’S MESSAGE](#)

[THE FIRST MAIL CAR IN DEWITT, IOWA WILL RIDE AGAIN](#)

[MODEL A OWNER IN HOPKINTON, MASSACHUSETTS TURNS 100](#)

[MODEL A FORD ARCHIVE CHANNEL HITS YOUTUBE WITH A SLASH](#)

RICHARD ALEXANDER OF LOMPOC WON PASADENA HS MAFCA’S CAR

REMEMBER TO PAY YOUR DUES OR YOU WON’T BE IN THE DIRECTORY FOR 2022.

The Message from President Ed



I look forward to being your president. Here we go again. First of all, a big round of applause to all those who kept last years club momentum going in the right direction. The new crew for this year is pretty much the same except for [Mark Greenlee](#) as our new vice president.

The biggest score last year was firming up a solid deal on a place to continue meeting, [Palomar Estates East](#).

On the technical side, the club now has a both a clarified website plan for www.palomarmodelclub.org and a increasingly popular Facebook group www.facebook.com/groups/palomarmafca.

The new Tech Talk by committee is going to be staffed by us all and could be interesting for sure. I'm going to sign up for a session soon. There is a lot of collective and diverse wisdom out there and every one of us has got enough B.S. potential to keep crowd attention for a little while!

The tour calendar is filling up and ideas for Saturday tours are more than welcome.

Our treasury looks solid again, but get your dues in for this year. Our monthly raffle generates revenue, recycles, and distributes good car stuff. Keep your contributions coming and practice your gaming skills for the good of the club.

The word's getting out there, thanks to an [award winning publication](#), and a tireless editor.

Above all, thanks are due Chuck for steering this lineup for the last three years. You always had an agenda and kept the meetings short and sweet. Board meetings were a good idea; they settled a lot of routine, bothersome business, and freed up group time to eat great and abundant goodies and catch up in real time on the important subjects.

If I missed anything, blame it on [floor-board fumes!](#)

Yup, that's me in the picture in my father's arms in 1945. In the background is his roadster pickup; the first Model A that I remember.

In future letters, I hope to include a few words as to how I arrived in this strange point in time in another roadster pickup.

Thanks, Ed Simpson, President.



A'ers meet for Annual Christmas/Installation

In an end-of-year party, the Palomar A's met for their annual Christmas/Installation Luncheon. Members met on Saturday, December 11th at the [Hunter Restaurant](#) in Oceanside. It was a great venue for getting together for socializing, a delicious lunch, and final accolades for the 2021 Board and activities.

We had 42 members join in, but we couldn't begin with our flag salute as we usually do when we get together, since we didn't have a flag in our separate room. But President Chuck Grabowski welcomed everyone and we had an hour to just chat and catch up with all the goings-on. At 12:30, lunch service began, so everyone found a place to sit.

Our meeting then began, with John Frazee presenting a special MAFCA award to David Frazee. This award is a whole new category. MAFCA looks at 140 newsletters and determines the best and/or most unusual newsletters. David's "Pandemic Press" won as a repeat winner for the most unusual newsletter. David also won our own Club award, the Golden Bird Award, which recognizes the outstanding contribution by a member of the Club for 2021. Chuck won the Drip Award, and he told us of finding oil on the side of his truck all the way to the rear fender, and what a disaster that was.

Chuck then presented Certificates of Appreciation to the 2021 Board Members.

All have done wonderful jobs, and they are very much valued. Then, it was time for the handing over of the gavel. Chuck called up incoming President Ed Simpson, and gave him a little history of our gavel. It was made in the early years of the Club by members Steve Curry, Richard Allen and Bob Barker.

Ed called up Bruce Howe, who presented a beautifully engraved [plaque to Chuck for three years of service](#). Bruce mentioned Chuck's work in helping keep our place to meet (still at the Palomar Estates East Meeting Room) and adding the additional job as Tech Director in addition to being President.

Then Ed presented the new Board for 2022, including new Vice President Mark Greenlee, Librarian change to Judy Burrell, and new Long Tour Director Bruce Howe. The Raffle came next, and Jon and Anna Velsaco did an excellent job of running our Christmas exchange. As a final item, dessert was served, delicious chocolate or vanilla cake.

It was a wonderful party; a perfect end to the year's activities. We have great plans to resume our usual single day touring and also take in several long tour events. All members are encouraged to come, driving a modern if their A is not quite ready!



What's Next for *The Reflector*?

There are the few things I'm going to add to this and future newsletters.

Right off the bat, you'll notice that the format has changed to landscape rather than portrait. This, and also the larger type, will hopefully further enhance your reading this newsletter on a computer. Blue links lead you to text pages and green links contain video.

I'm also back to having a table of Contents, with this one. In addition, though, you can just click on the page number link, and it will pop that page onto your screen. Below that are links outside of *The Reflector* that contain current Model A News stories and videos. I might still include some as filler, but this will allow you to check out more than I can ever include here first hand.

Further on you'll notice that the [calendar](#) is now taking a whole page so you can print just that one page out and tape it to your fridge as a reminder of future club events and member's occasions.

I want to link some articles to a [Palomar A's Club blog](#) to allow folks to make comments for others to appreciate and from which you can click and share on Twitter (and someday Facebook). I had problems being blocked by Facebook, though, so I am limited to only having a Facebook share button now, and it will only work in a few days, after Shiela has posted it. See what you get when you try clicking on this little box if you have a FB account, and then, please add a comment.

[Palomar Blog Link](#)



The tour the club *almost* took to Betty Crocker's

At our last meeting in November David proposed that we tour to either the Midway or the Betty Crocker home in Valley Center. Kyle Matthews and I really wanted to go to the Betty Crocker House, mainly to see what used to be Matilda's Mouse and is now called [the Brick n Barn](#) and full of antiques. Since the club wasn't going, we decided to go ourselves. Linda suggested I tell you about our little trip.

We had a great time in Valley Center which began mid morning with a lovely drive up there, parking and hearing live music coming from the area. Two men were singing and playing keyboards and a fiddle. We headed over to the outside vendors first, then went through the old barn next to Betty Crocker's home. We went through each room several times to make sure we hadn't missed anything! Kyle, a retired bilingual teacher in San Marcos, found several wonderful old books for children to add to her collection and to share with her two little granddaughters, Cora and Maddison.

I found a great old metal Pig chair, very heavy, that kept calling my name. I went back into that room at least 4 times looking at it. I mentioned it to Kyle and she convinced me to go-ahead and buy it or I would keep thinking about it. My sensible side made me wonder just what I would do with it and so I sat

down on it and decided it was comfortable and made me sit up straighter, so maybe I would use it as my ukulele chair. I liked the green upholstery on it too. I guess the deciding factor was that we were in Kyle's van so we had the room to bring it back home with us!

We stopped for lunch in Valley Center at a cute little Italian cafe we saw on our way home. It was such a fun day, going 'antiquing' which we love and spending a beautiful day together with friends.

Donna and Kyle



The Lightbulb's Golden Anniversary

Henry Ford, like many of us, was a collector. Starting as a child disassembling watches and other machines to see how they worked. As [he built his collection of inventions](#), he stored them in a spare office in his factory as early as 1907. He didn't seem to think he had reached the critical mass necessary to install it in a museum until the late teens. Then planning for that building, as well as collecting for what to display, took an additional decade. Then Ford, rather than building replica rooms, began collecting famous buildings in addition to the machines built there. The first ones arriving in Dearborn in 1928 and they became the nexus of Greenfield Village.

The [Henry Ford Museum](#) complex—then to be known as *The Edison Institute*—[broke ground September 27, 1928](#). The first roof rafters going up in May, 1929. The walls of the Independence Hall replica that fronts the main building, was completed in August.

Eventually, it would be ready to [open to the general public](#) on June 22, 1933, but Ford was excited about what he'd achieved already, and wanted to host a party as soon as things took shape.

The opportunity that presented itself that same year, was the Golden Anniversary

of the [first successful incandescent light bulb](#) invented by his longtime friend Thomas Edison on October 21, 1929.

The [Edison Institute was dedicated](#) by President Herbert Hoover with some 500 personal guests of Edison and Ford. It began with a program of the “history in the remaking” in person with [Edison at the reconstruction of his Menlo Park laboratory](#). Followed by a tour of the historic buildings and finishing with a plush banquet afterwards in the Independence Hall replica. The attendees included Marie Curie, George Eastman, John D. Rockefeller, Will Rogers, Charles Schwab, [Adolph Ochs](#), Walter Chrysler, J.P. Morgan, Orville Wright &, via short-wave radio from Berlin, Albert Einstein.

The reenactment was broadcast on radio with listeners encouraged to turn off their electric lights until the switch was flipped at the Museum.

This stunt was thought up by [Edward Bernays](#), the father of modern public relations (see [Era Fashions August, 2021](#) about hair nets). The entire spectacle was his, an all-out PR assault that included not only the celebratory events mentioned above, but also included a commemorative US postage stamp.

[Palomar Blog Link](#)



Long Tours

JANUARY 15TH Details to follow in group email. Destinations being considered are [Desert Flower Tour](#) to Borrego Springs, a visit to our namesake [Palomar Observatory](#) on Palomar Mountain (currently closed), or possibly a visit to [the Motor Transport Museum in Campo](#). Actual destination will depend on rain (needed for flowers to bloom), and what is in lockdown.

JANUARY 29TH-30TH [TURLOCK SWAP-MEET](#) in Turlock, Ca hosted by Modesto Area A's. Not a tour, but since we no longer have the Big-3 Swap Meet in San Diego, it is an opportunity to find those special parts. Take a rain coat and check snow forecasts for the Grapevine.

APRIL 3rd to 8th CCRG PASO ROBLES The registration forms and [hotel information](#) are now available on the MAFCA website. We will take two days going, the actual meet is April 5th and 6th, and two days returning. Jeanette and I have reservations in Paso Robles on April 4th, 5th and 6th at the Holiday Inn Express. Clyde is working on getting us an early tour at the [Seabee Museum](#) in Port Hueneme on our trip up. A seminar by Terry Burtz, builder of the New Model A Engine at CCRG.

The Spring Opener in Clear Lake. IF IT IS HELD, it will be April 29th,30th and May 1st.. The final decision if it is to be held will be made by February 1st. Please contact Bruce or Jeanette ASAP if you are interested.

January Club Activities

The Omicron (discovered in South Africa), Delta (discovered in Maharashtra, India), Beta (previously South African Variant), and Alpha (previously called the London) variants, all travel a lot more than we have, these past 18 months.

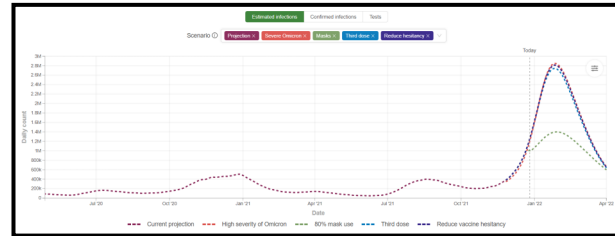

Sadly, we're not over the virus dominating our lives, either. The graph above is from the Institute for Health Metrics and Evaluation of past and anticipated Daily positive tests for COVID in the US from April 2020 to April 2022.

Last Christmas, just before the second lockdown, there were just under 600,000 positive tests per day. The IHME is predicting just under 3,000,000 per day in the month after Christmas this year. Good news is that [California ICU vacancy](#), other than the San Joaquin Valley, has been running twice what is needed before declaring a lockdown order. Even weeks after [Thanksgiving travel was 85%](#) of what it was back in 2019.

A betting man would expect a two month lockdown with both the January and Feb-

ruary meetings being cancelled as well as indoor dining cancelling our breakfast meetings, but we'll have to wait and see.

Local Tours

With no tour leader, we have tours by committee. We will ask for volunteers to organize future tours at our January Meeting on the 5th.

Long Tours

See article on the left.

Breakfast Meetings

This was a low stress opportunity for club members to socialize, and should continue. January 27th will be at the [Village Pie Shoppe](#) in Carlsbad.

Lunch Tours

In a Board discussion concerning the lack of a local tour leader and the overwhelming response to many local tours, it was agreed that the fun of tours was generally the social time and the lunches afterwards, rather than the sightseeing. It was suggested then, to forego the appointments and just arrange to meet with our cars at the Clubhouse and tour to our destination restaurant. The first of hopefully many, will be January 13th at 11 AM to [Nessy Burgers](#) in Fallbrook where Highway 76 and I-15 meet.

Muffler Tail Pipe Clamp

Have you ever wondered why the exhaust manifold on a Model A becomes distorted and leaks after years of operation—why the outlet of the manifold is no longer vertical? That condition is not normal; manifolds were not always that way.

There is a reason for this and it is not just because of continuous heating and cooling. Many people installing the [muffler](#) will tighten the [clamp bolt](#) where it fastens the muffler/tail pipe to the frame, obviously to keep it from rattling.

This bolt is only supposed to be little more than hand tight. That is the reason for the castellated nut and cotter pin—so that the bolt will not become un-screwed and fall off. The reason for this is to allow the tail pipe to slide forward and backward when the exhaust system is heated and cooled alternatively. If the clamp is over-tightened the exhaust manifold actually bends when the muffler expands.

I found multiple videos on [installing new mufflers](#), and none mention this, but yes, cast iron will ‘bend’ under these conditions. So remember, do not over-tighten your muffler/tail pipe clamp.

Source: *Tiny Tips For Your Model A*

Illustrations from [Aries Muffler](#) & [Eckler's](#) [Palomar Blog Link](#)

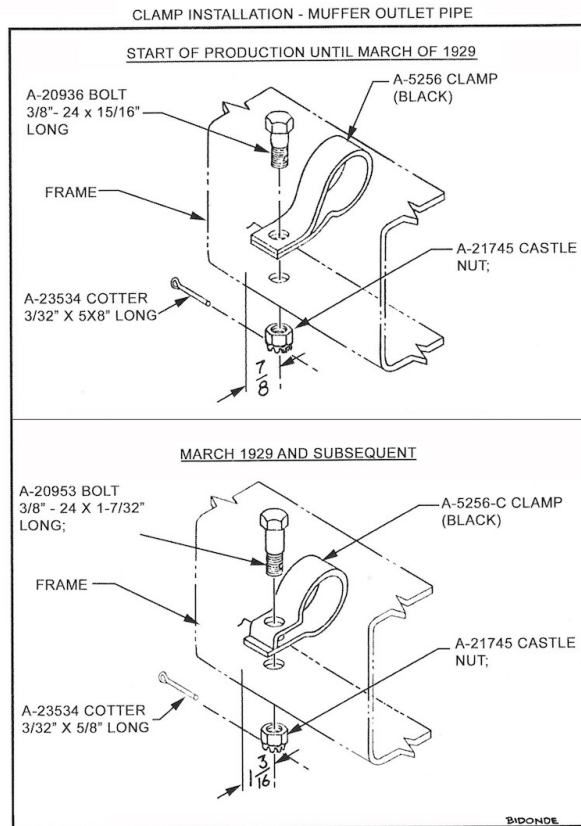

Illustrations by Bob Bidonde



Jim's Technical Tip

By Jim Gannon

LUBRICATING LOCKS

The best lubricant I have found for car door locks, trunk handle locks, and ignition locks, recommended by every locksmith that I know, is dry powdered graphite. You buy the



graphite in a small tube with a pointed tip. You insert the tip into the key hole and “puff” some graphite into the lock. Then you insert and remove the key several times to work the graphite into the lock tumblers, and operate the lock a few times.





ARIZONA MODEL A

15838 South Gilbert Road Chandler, Arizona 85225 (480)782-0266

Business Hours:

Tuesday - Friday: 9am - 12pm 1pm - 5pm	. New Parts . Used Parts . Service . Restoration
Saturday & Evenings: Appointment Only!	Owner: Sam Guthrie

FUTURE UPHOLSTERY SHOP AD



RANCHO BERNARDO
Print Pros
YOUR PRINT AND COPY CENTER

Mike Griffin
Owner

858-675-0770
Fax 858-675-0775
mikeg@rbprintpros.com
www.rbprintpros.com

11407 West Bernardo Court
San Diego, California 92127

FUTURE ENGINE REBUILDER'S AD

Join the
Model A Ford Club of America

- ◆ take part in National Events,
- ◆ receive *The Restorer Magazine* and
- ◆ get free classified advertising on the MAFCA.com

[Click Here](#) to download a MAFCA Membership Application. Print it out & send it with your \$50 check to

MAFCA
250 S. Cypress Street
La Habra CA 90631



Bill Hansen

Model A Ford Service & Repair

Proudly using KR Wilson Tools for



Dealership Quality

Day 760-789-8296
Evening 619-461-1001
lamesla@yahoo.com

14755 Mussey Grade Road
Ramona, CA 92065

Complete Rebuilding of: Engine, Transmission, Clutch, Rear end, Front end, Steering Box & Brakes. **Other Services:** Wheel Balancing, Counter Balanced Crank Shafts, Engine Babbitting, Lightened Fly-Wheels, V8 Clutches, Leakless Water Pumps, Carburetors, Distributors, Generators, Starters and More.

CALL FOR COMPLETE LIST OF SERVICES!

FUTURE RADIATOR REPAIRER'S AD

FUTURE POWDER COATING PAINTER AD

JANUARY 2022

Sunday	Monday	Tuesday	Wednesday	Thursday	Friday	Saturday
		<p>On January 4, 1929 the Victor Talking Machine Co. and RCA Corp. merged. The dog, Nipper, trademark belonged to Victor.</p> 				1 George Leitner
2	3 Steve Curry Kathy Glendinning	4 Anthony Lugo	5 Nancy Peterson Club Meeting at 7 PM	6	7 Doug Armstrong Judy Leitner	8 Christine Bartman
9	10 Jim Leary	11	12	13 Lunch Tour to Nessy Burgers	14 Chris Fuller	15 Long Tour to San Diego County Back Country
16	17 Kathy Horn	18	19 Glenn Boodry	20	21	22
23 Gerrie Rivera Betty ♥ Stoney Stonebreaker 30 John Giuliano	24/31	25	26	27 Breakfast at Village Kitchen & Pie Shoppe at 8 AM	28 Shiela Saxman	29 Howard Kruegel Turlock Swap Meet

2022 Palomar Model A Ford Club Board:

President 760-439-9103
Ed Simpson
Vice President 760-731-2501
Mark Greenlee
Treasurer 760-525-8993
Greg Wilson
Secretary 760-586-6554
Linda Thamer
Long Tour Dir. 858-692-4309
Bruce Howe
Short Tour Dir. 760-822-9523
Committee
Reflector Editor 760-822-9523
David Frazee
Public Relations 619-981-6523
Barbara Kruegel
Hospitality 760-650-5333
Donna & Anthony Lugo
Membership 760-729-4865
Vacant
Raffle Chair 760-798-4642
Jon & Anna Velasco
Librarians 949-492-4255
John & Judy Burrell
Tech. Director 760-439-9103
Committee
Web Master 951-696-0323
Sheila Saxman

PALOMAR MODEL A CLUB

North San Diego County
2410 Applan Rd
Carlsbad, CA 92010
Phone: 760-729-4865
Email: frazeetree@hotmail.com



The Palomar A's Club was founded in 1960 as a MARC affiliate, and elected Henry Jenkins as its first president for 1961. In 1963 it became a chapter of the Model A Ford Club of America, 250 South Cypress, La Habra CA 90631. Members of the club are encouraged to also join the national organization. Member registration and dues payment for MAFCA is available on www.MAFCA.dtm Palomar dues are \$20 per year



General meetings are held the first Wednesday of each month at the Palomar Estates East Clubhouse: 650 S Rancho Santa Fe Rd, San Marcos, CA. The doors open at 6:30 pm for social time and the meeting starts at 7:00pm. All Model A hobbyists are welcome to attend. Tours, shows, seminars, and social events are regularly scheduled throughout the year.

The Reflector is published in Escondido, CA after the 20th of each month with item deadlines on the 15th. For questions or to advertise on **The Reflector**, contact the editor, David Frazee at frazeetree@hotmail.com

2022 January

The Reflector

PLEASE
PLACE
STAMP
HERE

